

LECTURE 41 – ELECTRO PNEUMATICS

SELF EVALUATION QUESTIONS AND ANSWERS

1. A double acting cylinder is used for embossing slide rules as shown in **Figure 1**. The cylinder extends only when two push buttons are pressed simultaneously within two seconds to ensure the complete safety of operators. The cylinder should retract immediately if any of the push button is released. Develop a pneumatic circuit to implement the control task.

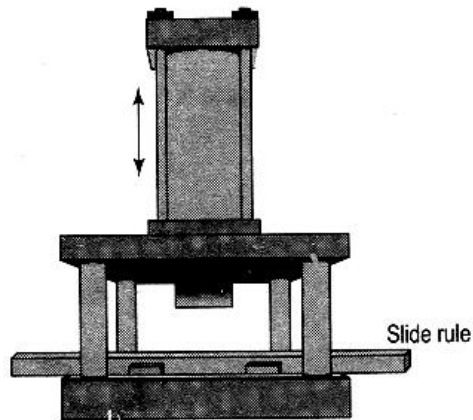

Figure 1

Figure 2 shows the arrangement for cleaning washers for injection pumps in a cleaning bath. A double acting cylinder is used to move the container filled with washers up and down in the bath several times. The operator provides a start signal manually. The washing operation is turned off automatically. The washing operation is turned off automatically after a preset time. Develop a pneumatic control circuit to implement this control task.

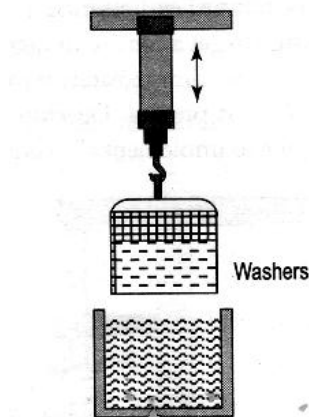

Figure 2

3. The schematic diagram of Assembly fixture for greasing of roller bearings is shown in Figure 3(a). After assembling individual roller bearing parts, roller bearings are to be pressed by a pneumatic cylinder A(1.0). Cylinder B(2.0) is required to operate a grease press twice for injecting grease into the roller bearing. The required sequence diagram is shown in Figure 2(b). Develop a pneumatic control circuit using Cascade method for implementing this control task.

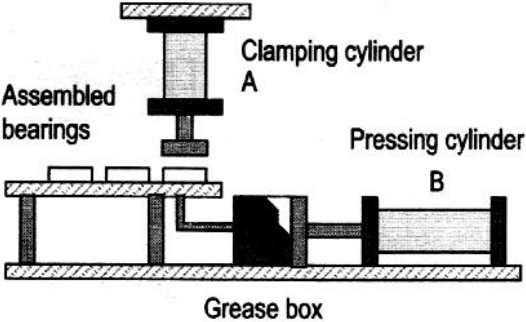

Figure 3(a) Assembly fixture for greasing of roller bearings

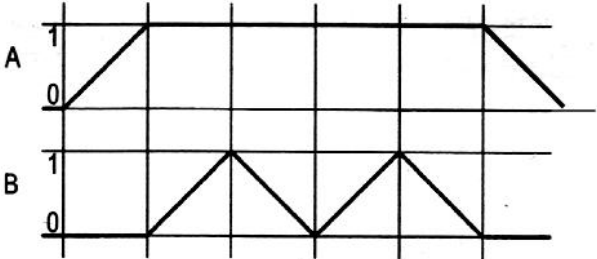

Figure 3(b) Displacement step diagram

Solution to Question No 1

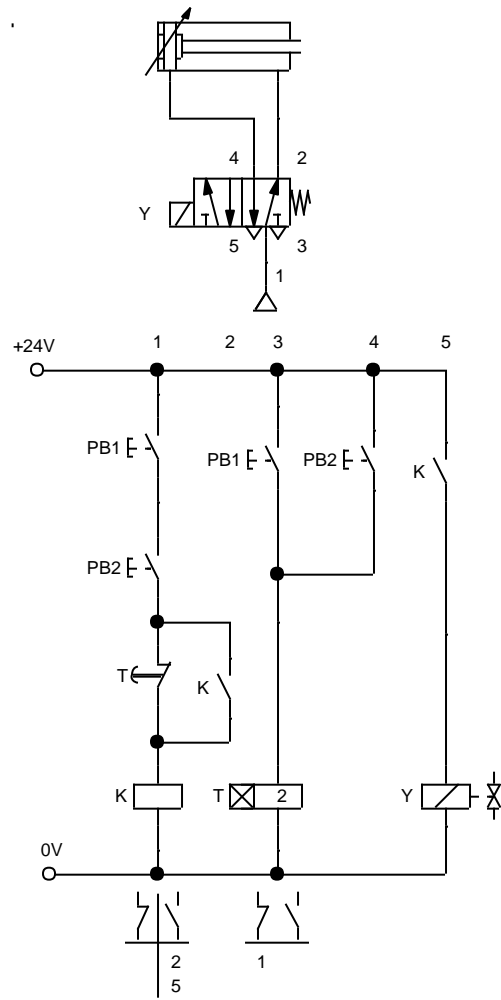
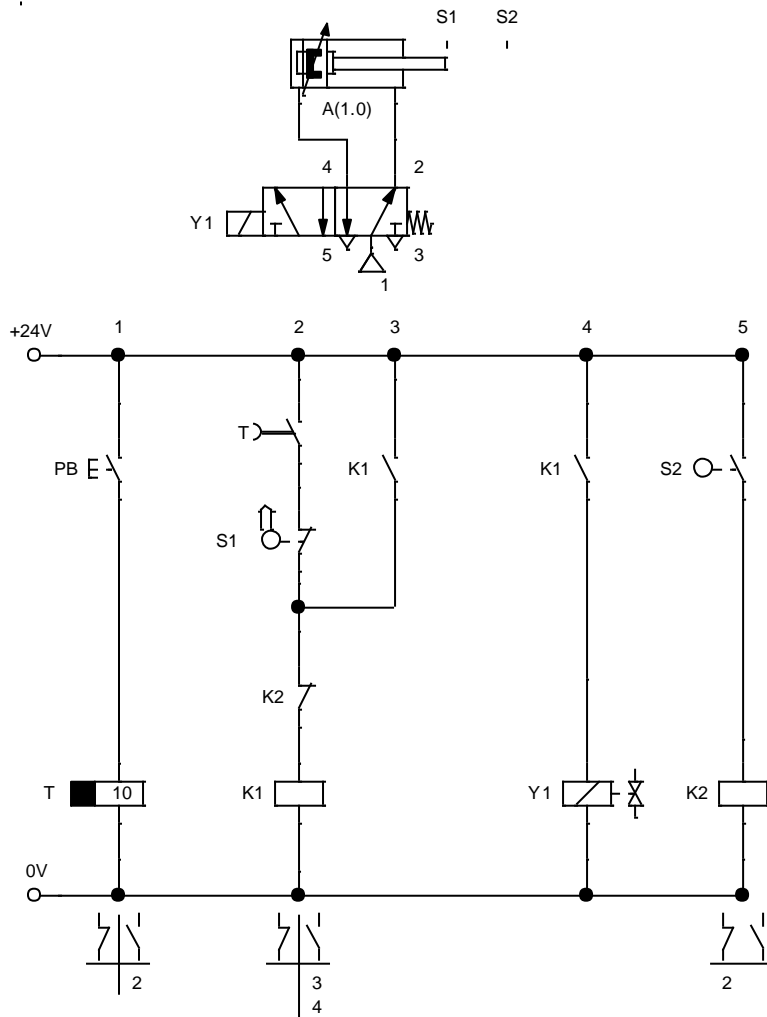

Figure S1

Solution to Question No 2



Solution to Question No 3

